



Project title

**Microcontroller Base Password Protected Door Lock System
Using Android Mobile Phone**

Supervisor

**Dr. Nahid Akhter Jahan
Assistant Professor
Department of Electronics & Communications
Engineering**

Submitted by

**Roman Ahamed Hiron
ID: 2010-3-55-012**

**Jamshadur Rahman
ID: 2010-3-55-022**

DECLARATION

We hereby declare that we carried out the work reported in this project in the Department of **Electronics and Communication Engineering, East West University**, under the supervision of **Dr. Nahid Akhter Jahan**. We solemnly declare that to the best of our knowledge, no part of this report has been submitted elsewhere for award of a degree. All sources of knowledge used have been duly acknowledged.

Signatur

.....
Roman Ahamed Hiron

Jamshadur Rahman

ID: 2010-3-55-012

ID:2010-3-55-022

.....

Supervisor

Dr. Nahid Akhter Jahan

Assistant Professor

Department of Electronics & Communications Engineering

APPROVAL

This is certify that the project titled as “**Microcontroller Base Password Protected Door Lock System Using Android Mobile Phone**” submitted to the respected members of the Board of Examination of the Faculty of Engineering for partial fulfillment of the requirement for the degree of Bachelor of Science in Electronics & Telecommunication Engineering by the following student and has been accepted as satisfactory.

Submitted By

Roman Ahmed Hiron

ID : 2010-3-55-012

Jamshadur Rahman

ID: 2010-3-55-022

Dr. Nahid Akhter Jahan
Assistant Professor, Dept. Of
Electronics and Communication
East West University
Engineering East West University

Dr. M. Mofazzal Hossain
Chairpersn & Associate professor,
Dept. Of Electronics and
Communication

ACKNOWLEDGEMENTS

There is many people who deserve our thanks for their help in completing this project. We would like to thank our department for giving us this

chance to do this project. We want to express our thanks and deep appreciation to our advisor **Dr. Nahid A Jahan** as she has exhausted all his knowledge and time by following up our daily progress and encouraging advice and even by sharing on the troubles.

We would like to extend our thanks to the laboratory staff of ECE Dept. for their fast response and cooperation with us to get some materials we need for our case.

We have special acknowledgement for our group members for their understanding each other and hard working for the beginning up to the end.

Finally, we would like to thanks all persons who were involved with this project for their valuable help and professionalism during this project.

ABSTRACT

Nowadays mobile phone is an important part of our life. And if the mobile is an android mobile then it is more important and useful in our

daily life. We can use an Android Mobile in various purpose. In this project, we have designed and developed a Microcontroller base Door lock system using Android mobile phone. We can control (Lock/Unlock) solenoid door lock (operated by 12V) by entering password on Android phone. Here, we used an Arduino UNO board as the main controlling unit, HC-05 Bluetooth module as Bluetooth sensor , transistor ,diode. A program has been developed and burnt into the microcontroller of the arduino module. This system is constructed and tested and found to work satisfactorily. The developed system can be used in any door even in vault. Finally the system can be used for other application with a little modification e.g., Alarm, or other security purpose.

TABLE OF CONTENT

Short Content	Page
TITLE PAGE	XX
DICLARATION	XX
APPROVAL	XX
ACKNOWLEDGEMENT	XX
ABSTRACT	XX
TABLE OF CONTENTS	XX
 CHAPTER	
1.INTRODUCTION	XX
I.I Energy	XX
I.II Electrical Energy	XX
I.III Using of Electronic device	XX
I.IV Purpose of this project	XX
I.V Outline of this report	XX
 2. An Over view of Micro Controller	
II.I Introduction	XX
II.II Microcontroller	XX
II.III Advantages of Microcontroller	XX
II.IV Arduino-UNO	XX
II.V Figure of Arduino-UNO	XX
II.VI History of Arduino	XX
II.VII Evaluation	XX
 3. Theory Behind The Project	
III.I Introduction	XX
III.II Architecture of Arduino-UNO	XX
• Power(USB/Berrel Jack)	XX
• Pins(5v,3.3v,GND,Analog,Digital,PWM,ARRF)	XX

• Reset Button	XX
• Power LED Indicator	XX
• TX RX LEDs	XX
• Main IC	XX
• Voltage regulator	XX
• Schematic Diagram	XX
III.III Getting Started With Arduino Software	XX
• The Integrated Development Software	XX
• IDE Parts	XX
III.IV TIP120 Transistor	XX
• Absolute Maximum Ratings	XX
• Characteristics	XX
III.V HC-05 Bluetooth Module	XX
• Pins	XX
• Hardware Features	XX
• Software Features	XX
• Schematic Diagram of HC-05 Module	XX
III.VI 1N4001 Diode	XX
• Features	XX
• Mechanical Characteristics	XX
III.VII Solenoid Door Lock	XX
• Description	XX
4. System Design And Analysis	XX
IV.I Introduction	XX
IV.II Hardware design	XX
IV.III Full Circuit Design	XX
IV.IV Equipment Used in this system	XX
IV.V Connection Of Adriano With HC-05 Module	XX
IV.VI Connection Of Solenoid Door Lock with Arduino	XX
IV.VII Software Design	XX
• Installing Arduino	XX
• Verifying the software	XX
• Arduino Language	XX
• Logic Diagram	XX
• Flow Chart	XX

5. Implementation	
V.I Implementation	xx
V.II Processing With Arduino With HC-05 Module	xx
V.III Connection Of Arduino	xx
V.IV Assemble The Circuit	xx
V.V Development of the whole System	xx
V.VI Product Commercialization	xx
6. CONCLUSION	
VI.I Conclusion	xx
APPENDIX	xx
REFERENCES	xx

Chapter 1

INTRODUCTION

I.I Energy

In physics, energy is a property of objects which can be transferred to other objects or converted into different forms. The "ability of a system to perform work" is a common description, but it is difficult to give one single comprehensive definition of energy because of its many forms. For instance, in SI units, energy is measured in joules, and one joule is defined "mechanically", being the energy transferred to an object by the mechanical work of moving it a distance of 1 meter against a force of 1 Newton. However, there are many other definitions of energy, depending on the context, such as thermal energy, radiant energy, electromagnetic, nuclear, etc., where definitions are derived that are the most convenient.

Common energy forms include the kinetic energy of a moving object, the potential energy stored by an object's position in a force field.[19]

I.II Electrical Energy

Electrical energy is the energy newly derived from electric potential energy or kinetic energy. When loosely used to describe energy absorbed or delivered by an electrical circuit (for example, one provided by an electric power utility) "electrical energy" talks about energy which has been converted *from* electric potential energy. This energy is supplied by the combination of electric current and electric potential that is delivered by the circuit. At the point that this electric potential energy has been converted to another type of energy, it ceases to be electric potential energy. Thus, all electrical energy is potential energy before it is delivered to the end-use. Once converted from potential energy, electrical energy can always be called another type of energy (heat, light, motion, etc.).[20]

I.III Using of Electronic device

If we see around us, we used lots of electronic devices in our daily life. Such as smart mobile phone. Its badly needed in every time. We can use

it many purposed by making call with other, doing sms. Taking a photo, doing video etc. we are using windows and android in our smart phone. There have lots of application for making our mobile smarter . Now we should think more . if we think to secure our door by using a door lock system . we can use this system in every door like office, school, home.

I.IV Purpose of this project

Now a days mobile is an important part of our life. If it's an android mobile then it is more effective and we can use it for various purpose in our daily life. Such as, Arduino based password protected door lock system using android mobile. We can unlock a door using android through Bluetooth. In this project we describe how to control and designing a microcontroller base door lock system using Android mobile phone. In our project we design a system which can lock and unlock a door without touching the door lock. We can use it in any door, Vault. For this project we use an Arduino-UNO, Bluetooth module, solenoid door lock, transistor, diode and Android mobile phone. The Door lock works when we enter the password from the mobile. As it is used define password protected door lock system so it's much safer then normal lock system.

I.V Outline of the report:

Here we describe four chapter on the purpose of this project. First we describe the introduction part that contains energy , electrical energy, purpose of this project. Chapter two contains overview of microcontrollers where we describe about Arduino-UNO, Bluet

Chapter 2

An over view of Micro controller

II.I Introduction :

Arduino is an open source electronics platform based on easy to use hardware and software. In this project we use an Arduino-UNO board. The Arduino hardware platform already has the power and reset circuitry setup as well as circuitry to program and communication with the microcontroller over USB. On addition, the I/O pins of the microcontroller are typically already fed out to sockets/headers for easy access. On the software side, Arduino provides a number of libraries to make programming the microcontroller easier. The simpler of these are functions to control and read the I/O pins rather than having to fiddle with the bus/bit makes normally used to interface with the Atmega I/O.

II.II Microcontroller:

A microcontroller is a small computer (SoC) on a single integrated circuit containing a processor core, memory, and programmable input/output peripherals. Program memory in the form of Ferroelectric RAM, NOR flash or OTP ROM is also often included on chip, as well as a typically small amount of RAM. Microcontrollers are designed for embedded applications, in contrast to the microprocessors used in personal computers or other general purpose applications consisting of various discrete chips. Microcontrollers are used in automatically controlled products and devices, such as automobile engine control systems, implantable medical devices, remote controls, office machines, appliances, power tools, toys and other embedded systems.[21]

II.III Advantages of Microcontroller:

- A) Microcontrollers act as a microcomputer without any digital parts.
- b) As the higher integration inside microcontroller reduce cost and size of the system.

- c) Usage of microcontroller is simple, easy for troubleshoot and system maintaining.
- d) Most of the pins are programmable by the user for performing different functions.
- e) Easily interface additional RAM, ROM,I/O ports.
- f) Low time required for performing operations.[22]

II.IV Arduino-UNO:

Arduino is a software company, project, and user community that designs and manufactures computer open-source hardware, open-source software, and microcontroller-based kits for building digital devices and interactive objects that can sense and control physical devices. The project is based on microcontroller board designs, produced by several vendors, using various microcontrollers. These systems provide sets of digital and analog I/O pins that can interface to various expansion boards (termed *shields*) and other circuits. The boards feature serial communication interfaces, including Universal Serial Bus (USB) on some models, for loading programs from personal computers. For programming the microcontrollers, the Arduino project provides an integrated development environment(IDE) based on a programming language named Processing, which also supports the languages C and C++.The first Arduino was introduced in 2005, aiming to provide a low cost, easy way for novices and professionals to create devices that interact with their environment using sensors and actuators. Common examples of such devices intended for beginner hobbyists include simple robots, thermostats, and motion detectors.Arduino boards are available commercially in preassembled form, or as do-it-yourself kits. The hardware design specifications are openly available, allowing the Arduino boards to be produced by anyone. Adafruit Industries estimated in mid-2011 that over 300,000 official Arduinos had been commercially produced,and in 2013 that 700,000 official boards were in users' hands.[23]

II.V Figure of Arduiono-UNO :



Figure of arduino-UNO [24]

II.VI History of Arduino:

Colombian student Hernando Barraging created the development platform Wiring as his Master's thesis project in 2004 at the Interaction Design Institute Ivrea in Ivrea, Italy. Massimo Banzi and Casey Reas (known for his work on Processing) were supervisors for his thesis. The goal was to create low cost, simple tools for non-engineers to create digital projects. The Wiring platform consisted of a hardware PCB with an ATmega128 microcontroller, an integrated development environment (IDE) based on Processing and library functions to easily program the microcontroller.

In 2005, Massimo Banzi, with David Mellis (then an IDII student) and David Cuartielles, added support for the cheaper ATmega8

microcontroller to Wiring. But instead of continuing the work on Wiring, they forked (or copied) the Wiring source code and started running it as a separate project, called Arduino.

The Arduino's initial core team consisted of Massimo Banzi, David Cuartielles, Tom Igoe, Gianluca Martino, and David Mellis.

The name Arduino comes from a bar in Ivrea, where some of the founders of the project used to meet. The bar was named after Arduin of Ivrea, who was the margrave of the March of Ivrea and King of Italy from 1002 to 1014.

Following the completion of the Wiring platform, its lighter, lower cost versions were created and made available to the open-source community. Associated researchers, including David Cuartielles, promoted the idea. Arduino's initial core team consisted of Massimo Banzi, David Cuartielles, Tom Igoe, Gianluca Martino, and David Mellis.

II.VII Evaluation

The PIC microcontroller board, introduced in 1985 by General Instruments, became one of the most popular tools for electronics enthusiasts (before the Arduino) for several reasons. Other popular boards for hobbyists include the BASIC Stamp (Parallax Inc., 1990), and Wiring (one of the first microcontroller boards designed specifically for electronic art and tangible media explorations) — both of which share the benefits of simplicity of programming, and a resulting ease of rapid-prototyping. The Arduino project grew largely out of the “DIY” climate created by the burgeoning popularity of rapid-prototyping boards like PIC and Wiring, as well as in response to an increasing need of artists and designers to easily prototype interactive works. In 2005, the Arduino team was formed in Ivrea, Italy, consisting of Barragan, Massimo Banzi, David Cuartielles, Dave Mellis, Gianluca Marino, and Nicholas Zambetti. The Arduino achieved rapid success even within its first two years of existence, selling in a quantity of more than 50,000 boards. By 2009, it had spawned over 13 different incarnations, each specialized for different applications — for example, the Arduino LilyPad (for wearable technologies projects), the Arduino Mini (miniaturized for use in small interactive objects), and the Arduino BT (with built-in Bluetooth capabilities).

Chapter 3

Theory Behind the Project

III.I Introduction

This project include with Arduino Uno board, Bluetooth device, Relay, Androide mobile Phone. We want to connect the Bluetooth device to an Arduino. We developed the connection

III.II Architecture Of Arduino-UNO

There are many varieties of Arduino boards that can be used for different purposes. The Arduino-UNO components are:



Figure 1.1: Arduino-UNO R3

(Power (USB / Barrel jack))

Arduino board needs a way to be connected to a power source. The Arduino UNO can be powered from a USB cable coming from your computer or a wall power supply that is terminated in a barrel jack. In the picture above the USB connection is labeled and the barrel jack is labeled. The USB connection is also how you will load code onto your Arduino board [1]

Pins (5V, 3.3V, GND, Analog, Digital, PWM, AREF)

The pins of Arduino are the places where connect wires to construct a circuit. Usually have black plastic ‘headers’ that allow justing plugging a wire right into the board. The Arduino has several different kinds of pins, each of which is labeled on the board and used for different functions. [2]

- **GND**: Short for ‘Ground’. There are several GND pins on the Arduino, any of which can be used to ground circuit.
- **5V (4) & 3.3V**: the 5V pin supplies 5 volts of power, and the 3.3V pin supplies 3.3 volts of power. Most of the simple components used with the Arduino run happily off of 5 or 3.3 volts.
- **Analog** : The area of pins under the ‘Analog In’ label (A0 through A5 on the UNO) are Analog In pins. These pins can read the signal from an analog sensor and convert it into a digital value that we can read.
- **Digital**: Across from the analog pins are the digital pins (0 through 13 on the UNO). These pins can be used for both digital input (like telling if a button is pushed) and digital output (like powering an LED).
- **PWM**: The digital pins (3,5,6,9,10 and 11) on the UNO are the PWM(~) pins. These pins act as normal digital pins, but can also be used for something called pulse-Width Modulation (PWM).
- **AREF (9)**: Stands for Analog Reference. It is sometimes used to set an external reference voltage (between 0 and 5 Volts) as the upper limit for the analog input pins.

Reset Button:

The Arduino has a reset button. Pushing it will temporarily connect the reset pin to ground and restart any code that is loaded on the Arduino. This can be very useful if code doesn’t repeat, but we want to test it multiple times. Unlike the original Nintendo however, blowing on the Arduino doesn’t usually fix any problems. [3]

Power LED Indicator

Just beneath and to the right of the word “UNO” on circuit board, there’s a tiny LED next to the word ‘ON’. This LED should light up whenever plug Arduino into a power source. If this light doesn’t turn

on, there's a good chance something is wrong. Time to re-check your circuit! [4]

TX RX LEDs

TX is short for transmit, RX is short for receive. In our case, there are two places on the Arduino UNO where TX and RX appear – once by digital pins 0 and 1, and a second time next to the TX and RX indicator LEDs. These LEDs will give us some nice visual indications whenever our Arduino is receiving or transmitting data. [5]

Main IC

The black thing with all the metal legs is an IC, or Integrated Circuit. The main IC on the Arduino is slightly different from board type to board type, but is usually from the AT mega line of IC's from the ATMEL company. This can be important, as may need to know the IC type before loading up a new program from the Arduino software. This information can usually be found in writing on the top side of the IC. [6]

Voltage Regulator

The voltage regulator is not actually something interact with on the Arduino. But it is potentially useful to know that it is there and what it's for. It controls the amount of voltage that is let into the Arduino board. It will turn away an extra voltage that might harm the circuit. [7]

Schematic Diagram

Arduino™ UNO Reference Design

Reference Designs ARE PROVIDED "AS IS" AND "WITH ALL FAULTS". Arduino DISCLAIMS ALL OTHER WARRANTIES, EXPRESS OR IMPLIED, REGARDING PRODUCTS, INCLUDING BUT NOT LIMITED TO, ANY IMPLIED WARRANTIES OF MERCHANTABILITY OR FITNESS FOR A PARTICULAR PURPOSE.

Arduino may make changes to specifications and product descriptions at any time, without notice. The Customer must not rely on the absence or characteristics of any features or instructions marked "reserved" or "undefined." Arduino reserves these for future definition and shall have no responsibility whatsoever for conflicts or incompatibilities arising from future changes to them. The product information on the Web Site or Materials is subject to change without notice. Do not finalize a design with this information.

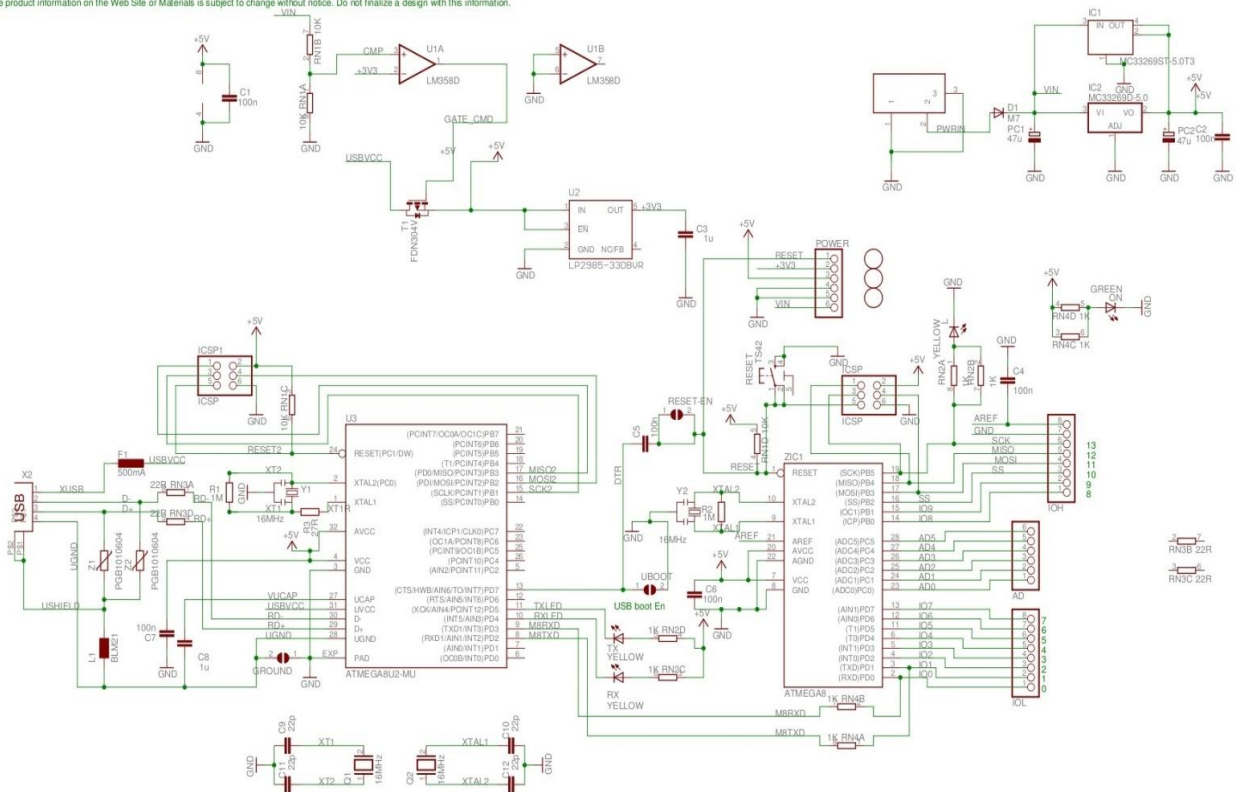

Figure : Schematic Diagram for Arduino Board [8]

III.III Getting started with Arduino Software

First Download and install the Arduino for Mac, Linux or Windows from arduino.cc. Windows users also need to install a driver. Connect your board via USB, Launch the Arduino application and select Arduino-Uno from the tools to board menu. Open the sketch File. Open Examples: 01 . Basics: Blink. Click the toolbar button to upload it to your board.

The Integrated Development Environment

Every microcontroller needs software to be programmed. The Arduino board is not a case apart. It has its own interested development environment (IDE). It is free and everyone can download it from its official website using either the Windows, Mac OS X or Linux Platform. That allows Arduino Board to gain more users and it also helps to grow.

IDE Parts

- **Compile:** Before program “code” can be sent to the board, it needs to be converted into instructions that the board understands. This process is called compiling.
- **Stop:** this stop the compilation process.
- **Create new Sketch:** This opens a new window to creat new sketch.
- **Open Existing Sketch:** This loads a sketch from a file on our computer.
- **Save Sketch:** This saves the changes to the sketch.
- **Upload to Board:** this compiles and then transmits over the USB cable to our board.
- **Serial Monitor:** Until this point when our programs (sketch) didn’t work, we just pulled out our hair and tried harder.
- **Tab Button:** this lets you creat multiple files in your sketch. This is for more advances programming than we will do in this.
- **Sketch Editor:** This is where write or edit sketches.
- **Text console:** This shows you what the IDE is currently doing and is also where error messages display if make a mistake in typing program.
- **Line Number:** This shows what line number you cursor is on.

III.IV TIP120 Transistor

Transistors are powerful little electronic switches, and when our little NPN transistors aren't power enough for your project, we have been known to use these beefy TIP120 Darlington transistors. Great for whenever we need to control medium to high-power electronics such as motors, solenoids, or 1W+ LEDs. We find them so handy, they come in a pack of 3!

Each transistor is a general purpose amplifier, model TIP120 and has a **BCE** pinout. They can switch up to 60V at peak currents of 8A (not continuously, just peak!) and continuous current of 5A, with a DC gain of about 1000. [11]

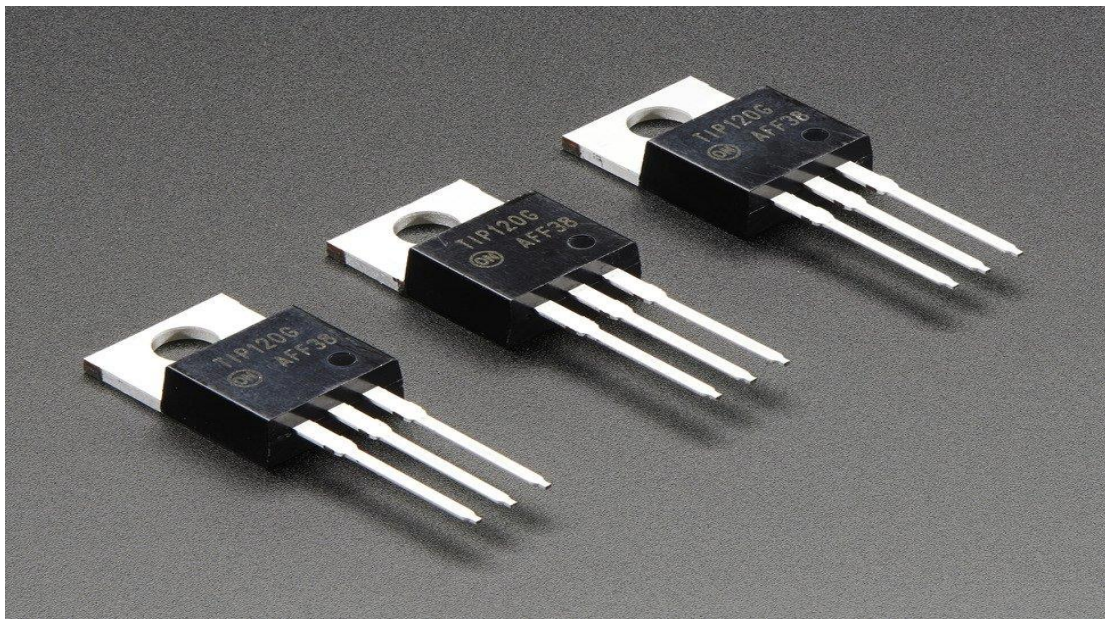

Figure : TIP120 transistor

Absolute Maximum ratings ($T_a = 25^{\circ}\text{C}$)

Symbol	Parameter	Value	Units
V_{CBO}	Collector-Base Voltage :TIP120	60	V
V_{CEO}	Collector-Emitter Voltage :TIP120	60	V
V_{EBO}	Emitter-Base Voltage	5	V
I_{C}	Collector Current(DC)	5	A
I_{CP}	Collector Current(Pulse)	8	A
I_{B}	Base Current (DC)	120	mA
P_{C}	Collector Dissipation($T_a=25^{\circ}\text{C}$)	2	W
P_{C}	Collector Dissipation($T_c=25^{\circ}\text{C}$)	65	W
T_{J}	Junction Temperature	150	$^{\circ}\text{C}$
T_{STG}	Storage Temperature	-65~150	$^{\circ}\text{C}$

Table : TIP120 Transistor [12]

Characteristics

Symbol	Parameter	Test Condition
$V_{CEO}^{(SUS)}$	Collector-Emitter Sustaining Voltage :TIP120	$I_C=100mA, I_B=0$
I_{CEO}	Collector Cut-off Current :TIP120	$V_{CE}=30V, I_B=0$
I_{CBO}	Collector Cut-off Current :TIP120	$V_{CB}=60V, I_E=0$
I_{EBO}	Emitter Cut-off Current	$V_{BE}= 5V, I_c=0$
h_{FE}	*DC Current Gain	$V_{CE}=3V, I_C=0.5A$ $V_{CE}=3V, I_C=3A$
$V_{CE}^{(Sat)}$	*Collector-Emitter Saturation Voltage	$I_C=3A, I_B=12mA$ $I_C=5A, I_B=20mA$
$V_{BE}^{(on)}$	*Base-Emitter ON Voltage	$V_{CE}=3V, I_c=3A$
C_{ob}	Output Capacitance	$V_{CB}=10V, I_E=0, f= 0.1MHZ$

III.V HC-05 Bluetooth Modules

HC-05 Bluetooth module is one of the most popular Bluetooth module used in embedded projects. It can be easily interfaced with Arduino Board. HC-05 module is an easy to use Bluetooth SPP (Serial Port Protocol) module, designed for transparent wireless serial connection setup. Serial port Bluetooth module is fully qualified Bluetooth V2.0+EDR (Enhanced Data Rate) 3Mbps Modulation with complete 2.4GHz radio transceiver and baseband. It uses CSR Bluecore 04-External single chip Bluetooth system with CMOS technology and with AFH(Adaptive Frequency Hopping Feature). It has the footprint as small as 12.7mmx27mm. Hope it will simplify your overall design/development cycle. [12]

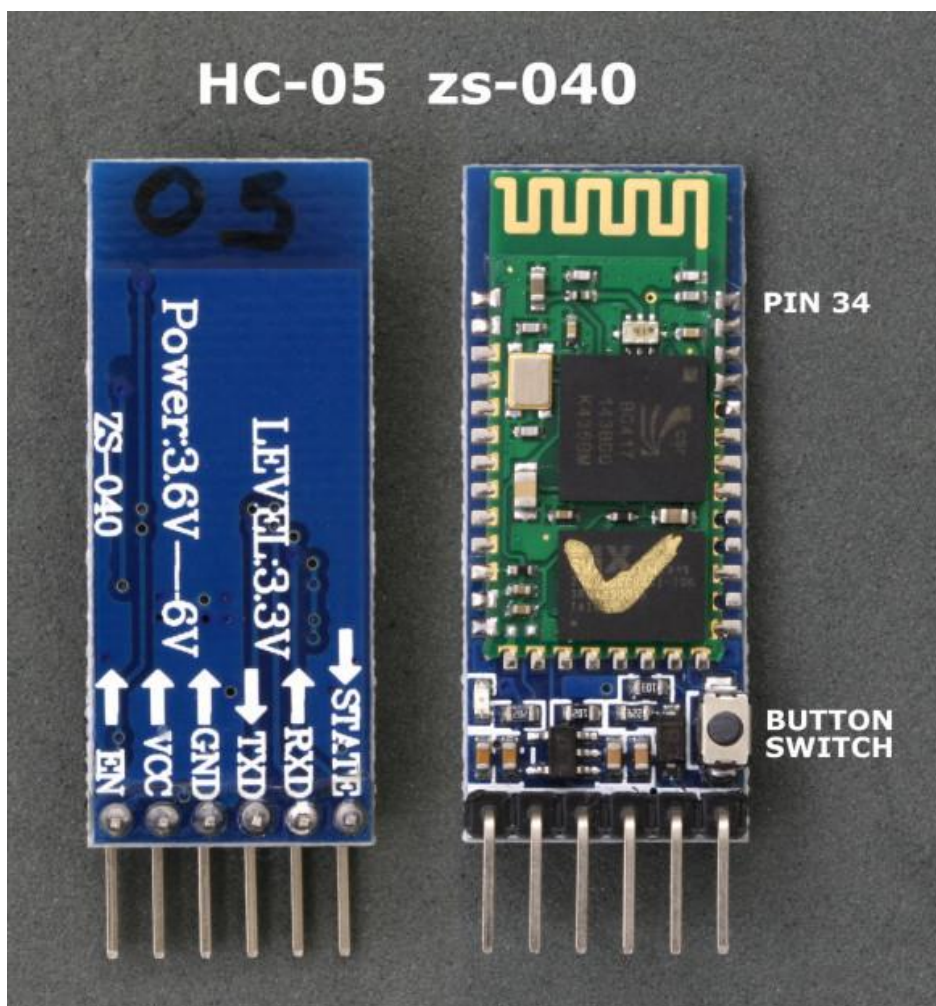

Fig: Bluetooth Module HC-05

Specification

Hardware Features

- Typical -80dBm sensitivity
- Up to +4dBm RF transmit power
- Low Power 1.8V Operation ,1.8 to 3.6V I/O
- PIO control
- UART interface with programmable baud rate
- With integrated antenna
- With edge connector. [13]

Software Features

- Default Baud rate: 38400, Data bits:8, Stop bit:1,Parity:No parity,
- Data control: has.
- Supported baud rate:
9600,19200,38400,57600,115200,230400,460800.
- Given a rising pulse in PIO0, device will be disconnected.
- Status instruction port PIO1: low-disconnected, high-connected;
- PIO10 and PIO11 can be connected to red and blue led separately.
When master and slave
- Are paired, red and blue led blinks 1time/2s in interval, while disconnected only blue led blinks 2times/s.
- Auto-connect to the last device on power as default.
- Permit pairing device to connect as default.
- Auto-pairing PINCODE:"0000" as default

- Auto-reconnect in 30 min when disconnected as a result of beyond the range of connection. [14]

Schematic Diagram of HC-05 Module

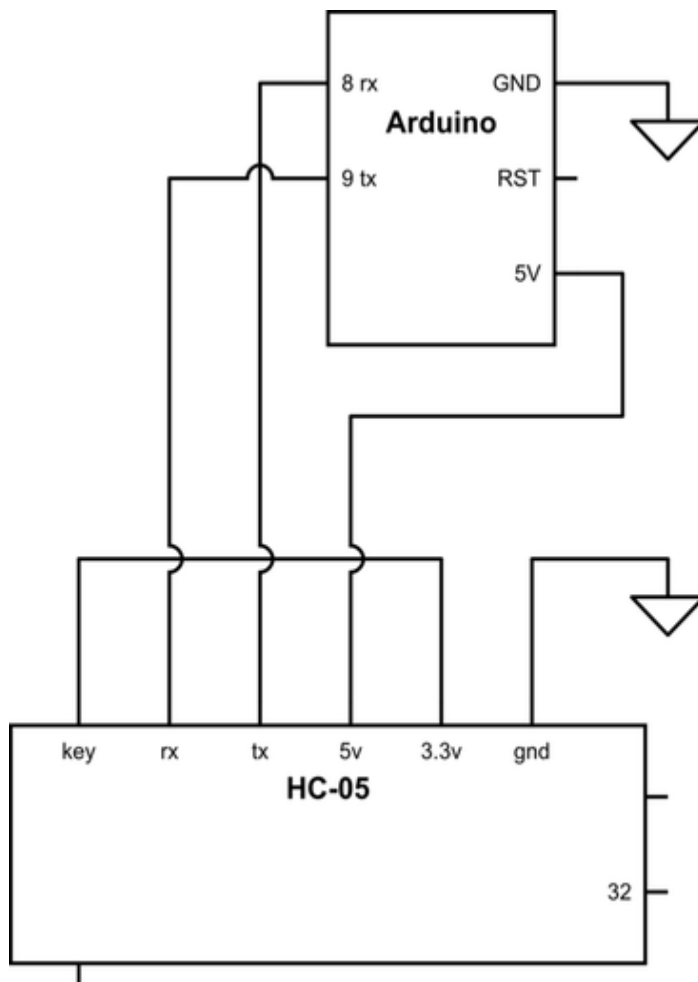

Figure : Schematic Diagram of HC-05 [15]

III.VI 1N4001 Diode:

1N4001 is a member of 1N400x diodes. Diode is a rectifying device which conducts only from anode to cathode. Diode behaves open circuited for the current flow from cathode to anode. 1N4001 is a 1A diode with low forward voltage drop and high surge current capability. It comprises of diffused PN junction and has low reverse leakage current of $5\mu\text{A}$. Its DC blocking voltage is 50V.

The cathode (n) is identified by a bar on diode case. The other terminal is the anode (p).[16]

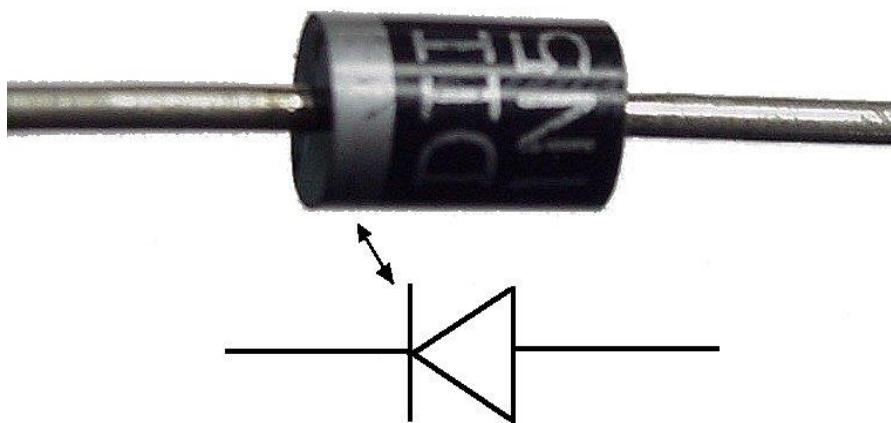

Figure : Diode [17]

Features:

Shipped in plastic bags, 1000 per bag

Available Tape and Reeled, 5000 per reel, by adding a “RL” suffix to the part number

Available in Fan-Fold Packaging, 3000 per box, by adding a “FF” suffix to the part number

- Pb-Free Packages are Available

Mechanical Characteristics

Case: Epoxy, Molded

Weight: 0.4 gram (approximately)

Finish: All External Surfaces Corrosion Resistant and Terminal Leads are Readily Solderable

Lead and Mounting Surface Temperature for Soldering Purposes: 260°C
Max. for 10 Seconds, 1/16 in. from case

- Polarity: Cathode Indicated by Polarity Band. [18]

III.VII Solenoid Door Lock

Description

Solenoids are basically electromagnets: they are made of a big coil of copper wire with an armature (a slug of metal) in the middle. When the coil is energized, the slug is pulled into the center of the coil. This makes the solenoid able to pull from one end.

This solenoid in particular is nice and strong, and has a slug with a slanted cut and a good mounting bracket. It's basically an electronic lock, designed for a basic cabinet or safe or door. Normally the lock is active so you can't open the door because the solenoid slug is in the way. It does not use any power in this state. When 9-12VDC is applied, the slug pulls in so it doesn't stick out anymore and the door can be opened.



Fig: Solenoid Door Lock

Chapter 4

System Design And Analysis

IV.I Introduction:

In this project helps those who interested to build something with arduino. To Design a project include into two parts, one is hardware and another part is software design. We use HC-05 bluetooth modules, Solenoid door lock , transistor, diode with the microcontroller. Arduino microcontroller is more suitable for establishing a new project including robotics. Arduino software is downloaded from www.arduino.cc and C/C++ programmable language is used. Many examples are given in the arduino.cc and this software is easy to usages.

IV.II Hardware design

The system is designed with a Arduino Uno with Bluetooth module HC-05 to receive password from the android mobile. And a solenoid door lock. In this project Arduino development board is more efficient.

IV.III Full Circuit Design:

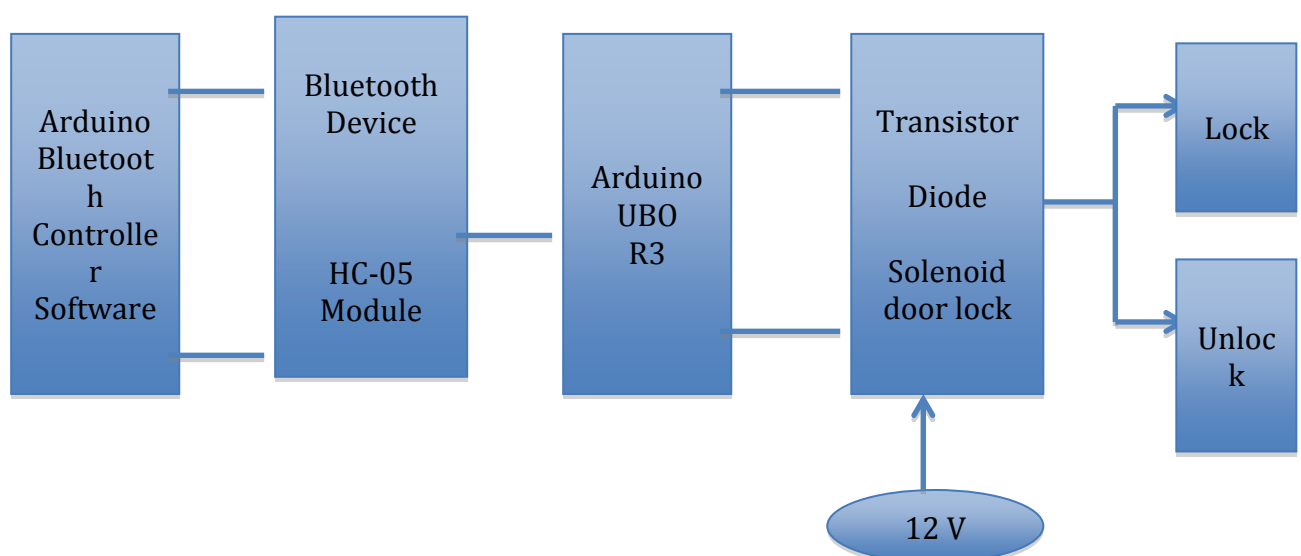

Figure: block diagram of the control system

Mainly we use some major component for designing the door lock system. The Bluetooth device receiving signal from android mobile phone and Bluetooth device connected to Arduino UNO board. A solenoid Electric Door Lock is connected to Arduino through TIP120 transistor. The output will be shown by Lock/Unlock the door.

IV.IV Equipments Used in this system

To design the project we use following components:

1. One Arduino UNO board.
2. One bread board.
3. Hc-05 Bluetooth Module.
4. 1N4001 Diode.
5. TIP120 transistor.
6. Solenoid Door lock (12V DC)
7. Power Supply.
8. Hookup Wire
9. An Android Mobile phone.

IV.V Connection Of Arduino With Bluetooth HC-05 Module

Here we have shown connection that we have done in this project. We also developed a connection of Bluetooth device with mobile phone. First, we think about android mobile phone software which will be appropriate for this project. We install Arduino Bluetooth Controller Software on our mobile phone. Then we connect the software with HC-05 Bluetooth module.

After connecting software we developed the connection between Arduino and Bluetooth device. We run a program on Arduino Board for implementing the project.

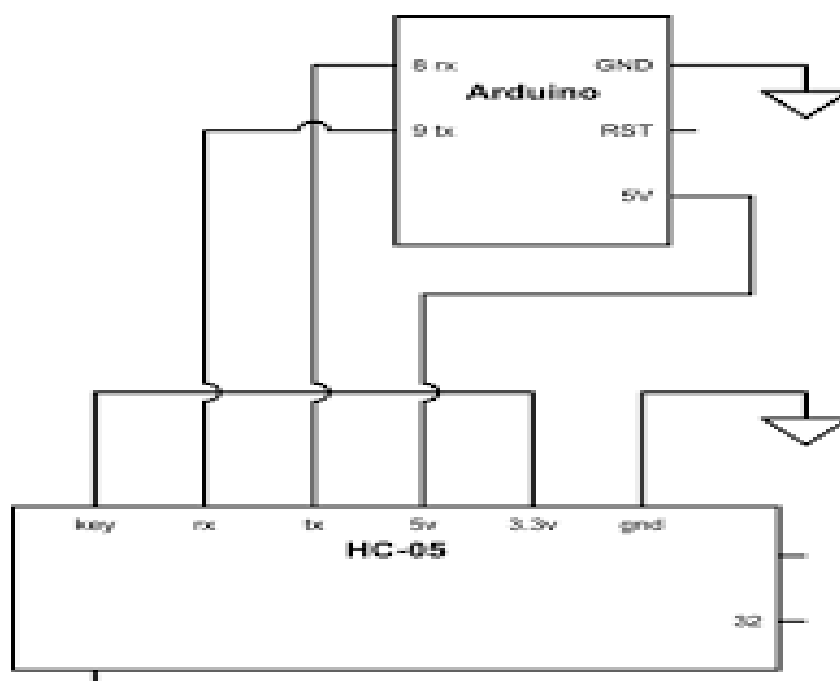

Fig: vircuit Diagram of The Arduino with Bluetooth Device.

IV.VI Connection of the Solenoid Door lock with Arduino

We use solenoid door lock which is connected to a 12V dc power supply. The solenoid door lock is connected to the Arduino pin 9 through TIP120 transistor. The transistor is connected to a diode.

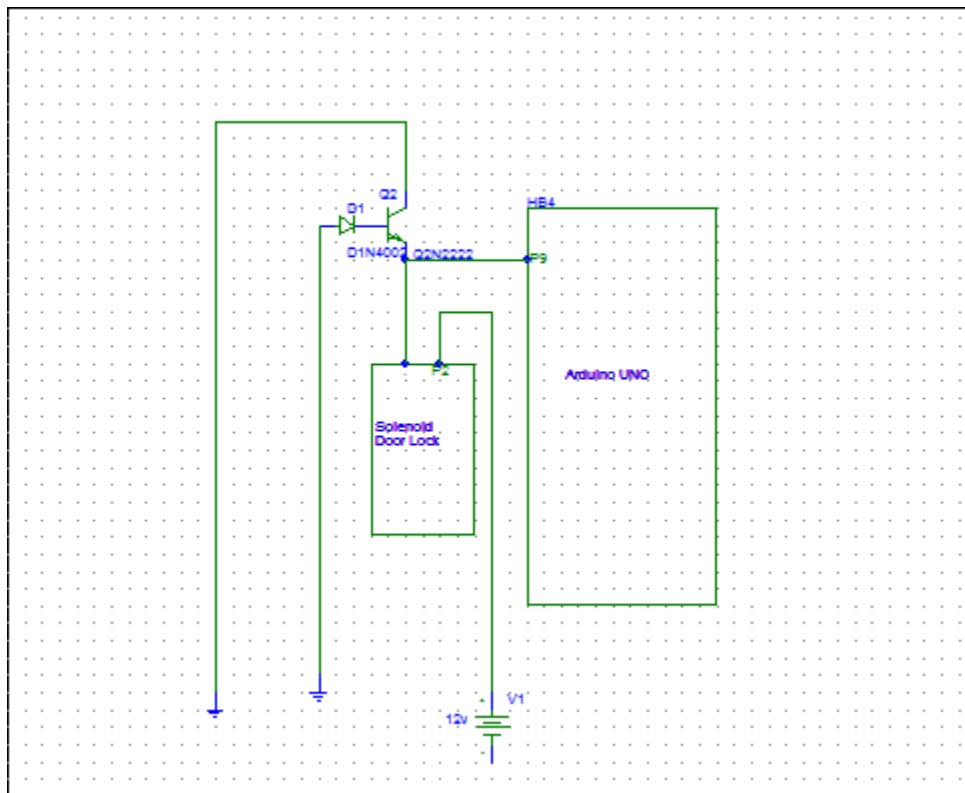

Figure: Connection of the Solenoid door lock

V.VII Software Design

Software design is divided into two parts. First we write the Arduino program in Arduino software. Then we compile it to the Arduino hardware. This Arduino command is control the Arduino hardware and other circuit connection. For making connection between Arduino and

arduino mobile we needed to install Arduino Bluetooth controller software on our mobile phone.

Installing Arduino

Arduino runs on Windows. Go to the Arduino software web site at <https://arduino.cc/en/Software> and download the version of the software compatible with our system. We use Arduino 1.0.5 version.

Verifying the software

Now that we have the Arduino IDE software installed, let's connect the computer to the mc board, load a small program, and verify that all components are working together. Frist, need to connect the USB cable to our mc board and then plug the other end of the USE cable into our computer.

Arduino Language

The Arduino language is implemented in C/C++ and based in wiring. When we write an arduino sketch, we are implicitly making use of the wiring library , which is included with the arduino IDE. This aiiows us to make run able program by using only two functions:setup () and loop (). As mentioned,the wiring language is inspired by processing, and the Arduino language structure is inherited from the processing language, where the equivalent functions arew called seyup ().we need to include both functions in every arduino program, even if we don't need one of them. Let's analyze the structure of a simple Arduino Sketch using again yhe Blink example.

Logic Diagram

We have a logic diagram for this project. Here android mobile phone works as a input signal which start from beginning part. We have got output from electric device.

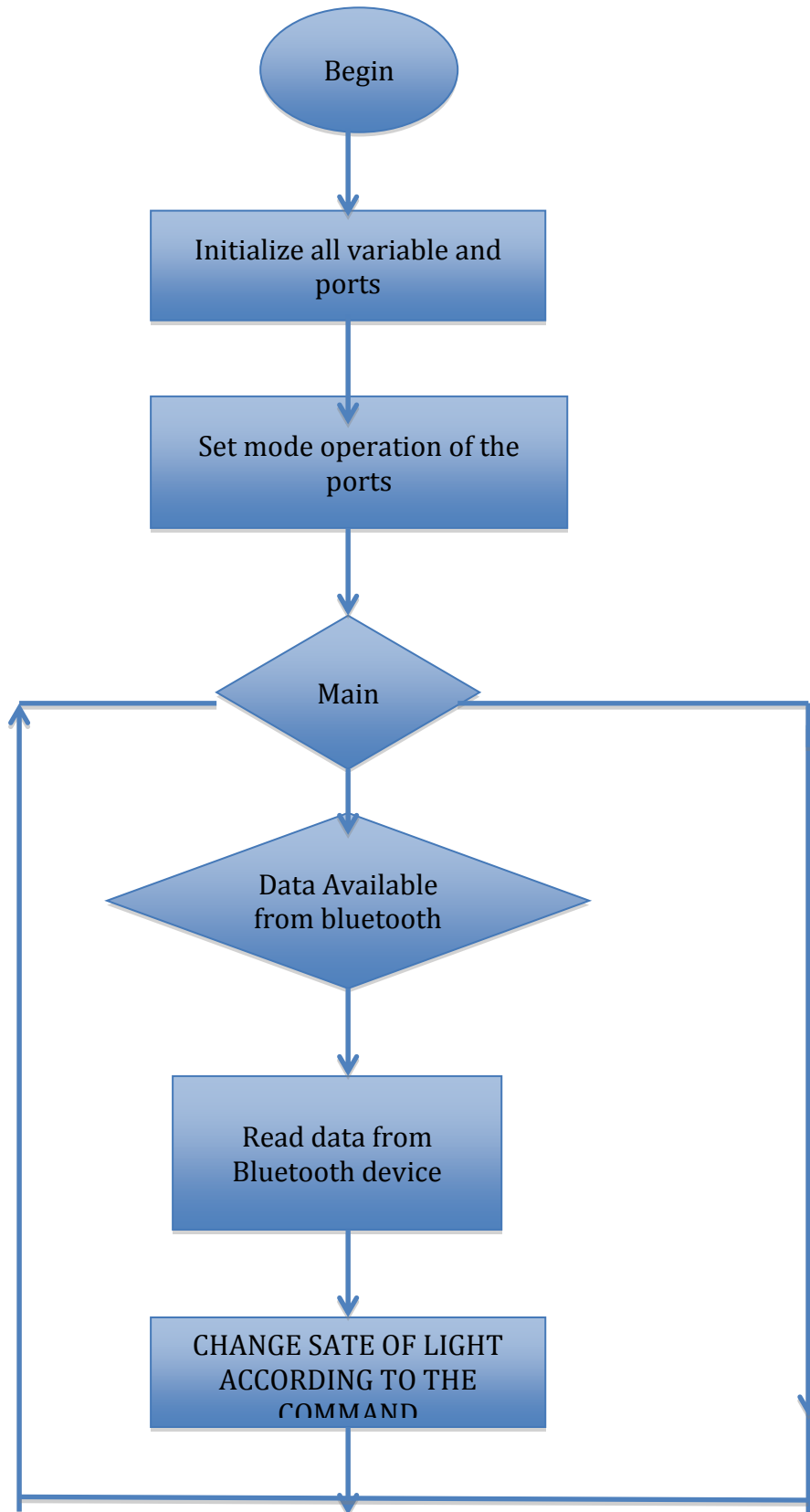
Flow Chart:

Chapter 5

IMPLEMENTATION AND RESULT

V.I Implementation

All the parts are connected as circuit design. Then we upload the programming code in the arduino and we get positive result. It works properly according to our design.

V.II Processing on Androide with Bluetooth Device HC-05

Bluetooth connection was first task in this project. Because we have to give a input signal from mobile phone to Arduino board via Bluetooth. For proper connection we read the properties of HC-05 Bluetooth modules from Google. We design connection between Arduino and HC-05 Bluetooth module as we learned from properties. We developed the connection successfully. Here we represent the photo of this connection.

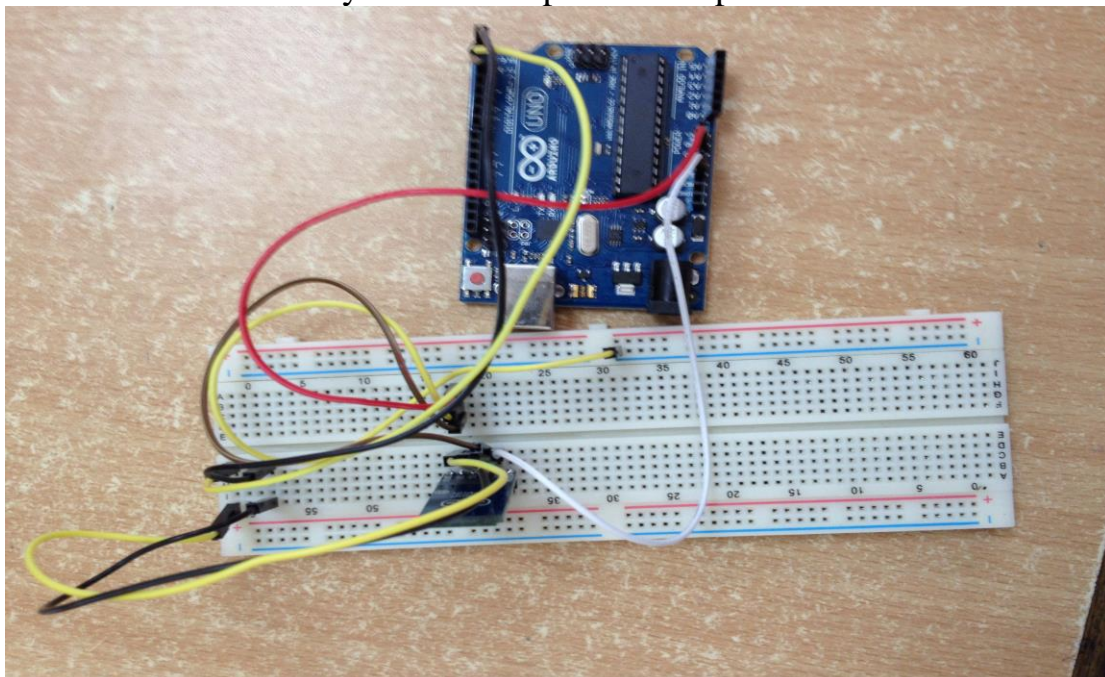

V.III Connection of transistor

We'll start by focusing on one of the main components of the circuit, the transistor. Our transistor will allow us to control a device that requires more current than our Arduino can supply, by sending the transistor different values. The type of transistor we are using (the TIP120) has a base, collector, and an emitter which are labeled here. We will send the signal from pin 9 on the Arduino to the base of the transistor, and depending on the value sent, current will increase or decrease.

V.IV Assemble the circuit

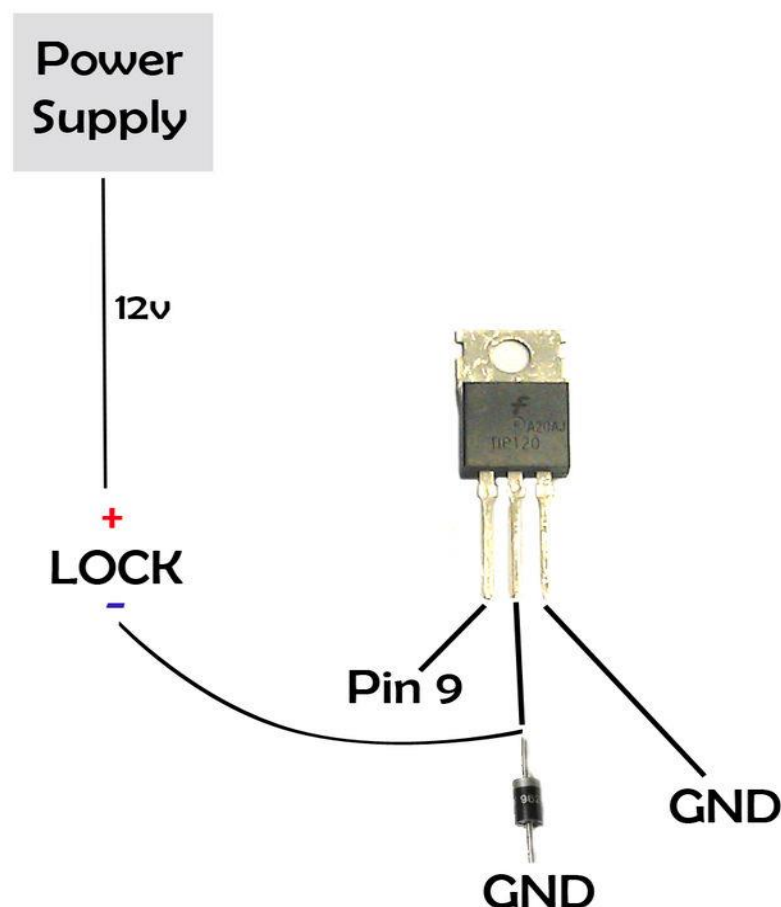

The diagram shows how the transistor is wired up in our circuit. As you can see, we have a diode pointed away from ground that is connected to the collector of the transistor as well as the ground of the lock itself.

This diode will protect our electronics from any back voltage that might be created when our lock is turned off. At this point you could set pin 9 to high or low to control the lock

V.V Development of the Whole system

In this stage we developed the main connection of this project. We said as last part of about without door lock. Now we connect the transistor Base with Arduino Pin 9 and the also connect the door lock negative weir to the Base of the transistor. And the diod is connected to the Collector of the transistor and the GND. The door lock is connected to a 12V Dc supply. After all successful connection we will output as lock/unlock. We can lock/unlock the door using android mobile phone. Here er represent the photo of the connection.

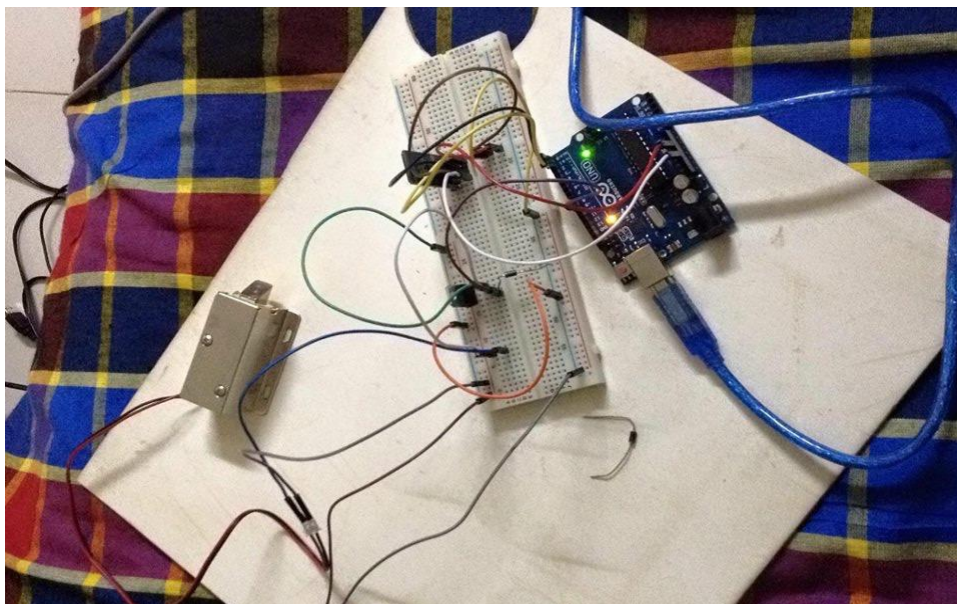

V.VI Product Commercialization

After completing all the circuit and developing the control system, we connected this control system in a door to saw that it works properly. Therefore we can say that Password protected Door Lock Using Android Phone is ready for commercial use.

Chapter 6

CONCLUSION

VI.I Conclusion

The password protected Door Lock using Androide Phone has veen designed and developed for making our life more easy and secure. We use 3.3v from Arduino and 12V DC power supply for Solenoid Door Lock. We use the HC-05 Bluetooth module for receiving signal from an android mobile phone. Finally, we have designed and developed the whole control system and tested using Androide mobile phone. We fixed all the problems encounyered during the design and testing of the system. Finally, we successfully achive our goals.

In this study, the application of microcontroller with improve algorithm of extended specifications has increased the use of android mobile phone and improves the controlling the electric device. The developed Door Lock system is effective and production cost is low. So, our Digital Door Lock System Using Android Mobile Phone is suitable for commercial use.

APPENDIX

Programming code for This System:

```

int unlock = 9;      //pin 9 on Arduino
int alarm = 10;
char final[4];      //Characters the Arduino will receive
char correct[4] = {'A','B','C','D'}; //User-Defined Password
int pass_correct = 0; //Does Password match, 0=false 1=true

void setup()
{
pinMode(unlock, OUTPUT);
Serial.begin(9600);
digitalWrite(unlock, LOW); //By default, lock is active(locked)
}

void loop()
{
while(Serial.available())
{
for(int i=0; i<4; i++) //While data is available read 4 bytes
{
final[i] = Serial.read(); //Read 4 bytes into the array labled "final"
}

for(int i=0; i<4; i++)
{
if(final[i]==correct[i]) //Compare each char received to each car in our
password in order
{

```

```
    pass_correct = 1; //If we compare two chars and they match, set the
pass_correct variable to true(1)
}
else
{
    pass_correct = 0; //if the two compared chars do NOT match, set
pass_correct variable to false(0)
    break; //End loop and stop comparing chars
}
}
}
```

```
if(pass_correct==1) //If all chars compared match, deactivate(unlock)
the lock for 5 seconds
```

```
{
    Serial.println("Unlocked");
    digitalWrite(unlock, HIGH);
    delay(10000);
    Serial.println("Locked");
    pass_correct = 0;
}
else
{
    digitalWrite(unlock, LOW); //Else if there was not a complete match,
keep the lock
    Serial.println("Wrong Password");
    digitalWrite(alarm, HIGH);
    delay(5000);
    high(locked)
}
```

```
/* FOR TESTING
```



```
Serial.print(final[0]);Serial.print(final[1]);Serial.print(final[2]);Serial.print(final[3]);
Serial.print(" | ");
Serial.print(correct[0]);Serial.print(correct[1]);Serial.print(correct[2]);Serial.print(correct[3]);
Serial.print(" ");
Serial.print(pass_correct);
Serial.println("");
*/
delay(500);

}
```

References

- [1] <https://learn.sparkfun.com/tutorials/what-is-an-arduino/whats-on-the-board>
- [2] <https://learn.sparkfun.com/tutorials/what-is-an-arduino/whats-on-the-board>
- [3] <https://learn.sparkfun.com/tutorials/what-is-an-arduino/whats-on-the-board>
- [4] <https://learn.sparkfun.com/tutorials/what-is-an-arduino/whats-on-the-board>
- [5] <https://learn.sparkfun.com/tutorials/what-is-an-arduino/whats-on-the-board>
- [6] <https://learn.sparkfun.com/tutorials/what-is-an-arduino/whats-on-the-board>
- [7] <https://learn.sparkfun.com/tutorials/what-is-an-arduino/whats-on-the-board>
- [8] <https://www.quora.com/How-does-the-arduino-work-What-does-each-component-do-How-does-it-all-come-together>
- [9]
- [10]
- [11] <https://www.adafruit.com/products/976>
- [12] [http://wiki.iteadstudio.com/Serial_Port_Bluetooth_Module_\(Master/Slave\) : HC-05#Overview](http://wiki.iteadstudio.com/Serial_Port_Bluetooth_Module_(Master/Slave) : HC-05#Overview)
- [13] [http://wiki.iteadstudio.com/Serial_Port_Bluetooth_Module_\(Master/Slave\) : HC-05#Overview](http://wiki.iteadstudio.com/Serial_Port_Bluetooth_Module_(Master/Slave) : HC-05#Overview)
- [14] [http://wiki.iteadstudio.com/Serial_Port_Bluetooth_Module_\(Master/Slave\) : HC-05#Overview](http://wiki.iteadstudio.com/Serial_Port_Bluetooth_Module_(Master/Slave) : HC-05#Overview)

[15] https://www.google.com/search?q=Schematic+Diagram+of+HC-05+Module&source=lnms&tbm=isch&sa=X&ved=0ahUKEwiDzNORzpbMAhWIm5QKHaeYBa0Q_AUIBygB&biw=1366&bih=667#imgrc=ftOJtgYIYFWQFM%3A

[16] <http://www.engineersgarage.com/electronic-components/1n4001-diode>

[17] https://www.google.com/search?q=what+is+1N4001+Diode&biw=1366&bih=667&source=lnms&tbm=isch&sa=X&ved=0ahUKEwiJut7A0pbMAhXFEpQKHVfnAzIQ_AUIBygC#tbn=isch&q=+1N4001+Diode&imgdii=4P6218_L5ox-bM%3A%3B4P6218_L5ox-bM%3A%3BDt6f4l_55UUqgM%3A&imgrc=4P6218_L5ox-bM%3A

[18] <https://cdn-shop.adafruit.com/datasheets/1N4001-D.PDF>

I.